



## HYBRID EYESAFE LASER RANGEFINDER RECEIVER

- OUTSTANDING SENSITIVITY DOWN TO 2 nW
- HERMETIC TO-8 PACKAGE, 0.1 CU INCH
- FAST RECOVERY – LOW MINIMUM RANGE
- DUAL WAVELENGTH InGaAs APD DETECTOR
- SINGLE SUPPLY, ONLY 95 mW
- LOW COST



### DESCRIPTION:

The **Model 755A-04.1** hybrid eyesafe laser rangefinder receiver is designed for laser ranging/surveying equipment. Because of the compact construction (Modified TO-8 header) and the PCB mounting capability, it is ideal for miniature applications. Fast recovery from T<sub>o</sub> overload allows ranging to close objects without compromising long range performance. The incorporation of an InGaAs APD gives very high sensitivity with time programmed gain to minimize false targets. Operation at both 1.06  $\mu\text{m}$  and 1.54  $\mu\text{m}$  is possible over a wide range of pulse widths.

### SPECIFICATIONS:

All measurements made at 20°C

PARAMETER		Min.	Typical	Max.	Units
InGaAs APD Active Diameter		195	200	205	$\mu\text{m}$
Sensitivity (1.54 $\mu\text{m}$ , 6 ns pulse, 50% Pd, 0.1% FAR)*		6	8	10	nW
Sensitivity (1.54 $\mu\text{m}$ , 20 ns pulse, 50% Pd, 0.1% FAR)*		2	3	4	nW
Low Gain Sensitivity (1.54 $\mu\text{m}$ Optical, 50% Pd, 20 ns pulse)		0.6	2	4	$\mu\text{W}$
Time Programmed Gain (TPG) (see application note)		25	28	30	dB
Target Separation (1:1 power ratio) (see application note)		-	12	-	m
Output (TTL or CMOS compatible, negative logic)	HI	2.4	3.3	4.5	V
	LOW	0	0.5	0.6	V
Supply Voltage		+4.95	+5.1	+12.6	V
Current Draw @ High Gain		8	10	11	mA
Current Draw @ Low Gain		18	19	21	mA
APD Bias Voltage (Pin 10)		30	70	82	V
Bias Current into Pin 10 (see application note)		10	20	80	$\mu\text{A}$
Operating Temperature	@ +5V	-40	-	+72	°C
Storage Temperature		-55	-	+100	°C
MTBF (Ground benign at 55°C per Telcordia SR-332)			150,000		Hours
Size			0.6 $\varnothing$ x 0.425		Inches
Weight			0.14 oz. (4.1 grams)		

\*At 1.06  $\mu\text{m}$ , multiply sensitivity value by 2.

Specifications subject to change without notice

### APPLICATIONS:

*Laser Ranging and Surveying*

"In the event this commodity will be transferred to a "foreign person" as defined in 22 CFR 120.16, either outside or within the United States, a validated US State Department license is required."



# OPERATING NOTES:

See application notes for detailed operating information.

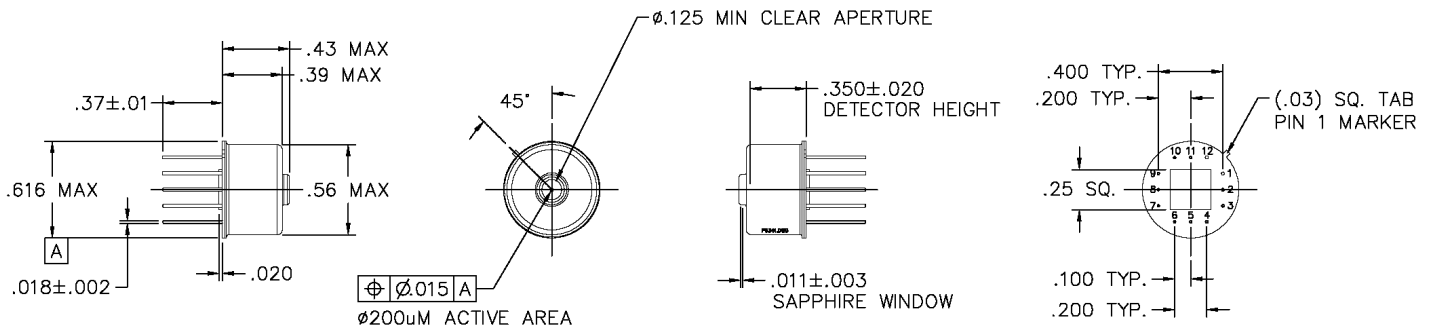
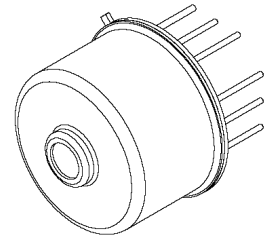

P8341A

Refractive Index of Window = 1.746 at 1.550  $\mu\text{m}$  and 1.754 at 1.064  $\mu\text{m}$